

# VERTO

# 845E10 - 845E20

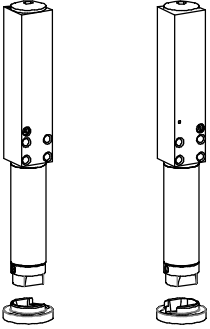
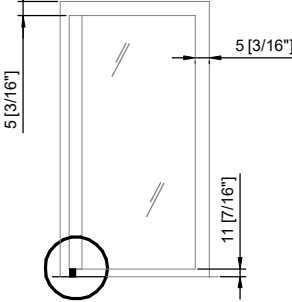
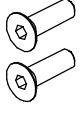
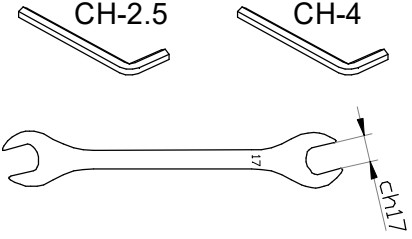

<p>845E10L 845E10R</p> 	<p>Suggested Sugerito Empfohlen</p> 	<p>Fittings required Fissaggi richiesti Benötigtes Befestigungsmaterial</p>  <p>minimum 2x M6</p>	<p>Tools Required Strumenti Richiesti Benötigtes Werkzeug</p> 
--	---	--	---

## 1

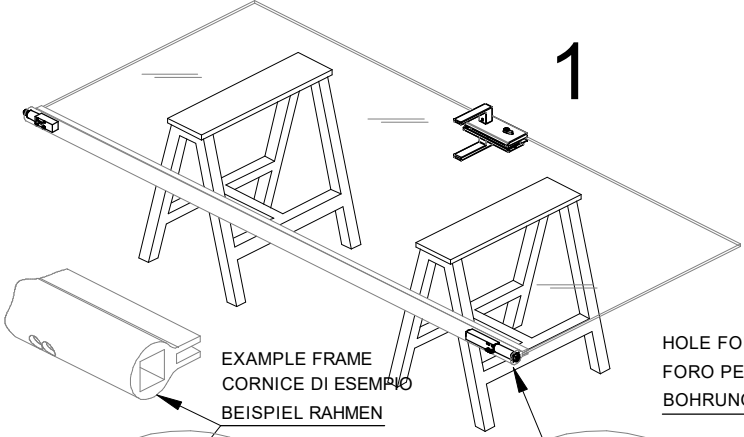

HOLE FOR SPEED REGULATION:  $\varnothing 4 -0+0,5$   
 FORO PER REGOLAZIONE VELOCITÀ:  $\varnothing 4 -0+0,5$   
 BOHRUNG FÜR GESCHWINDIGKEITSREGELUNG:  $\varnothing 4 -0+0,5$

M6 FIXING HOLES  
FORI DI FISSAGGIO M6  
M6 ANSCHRAUBPOSITIONEN

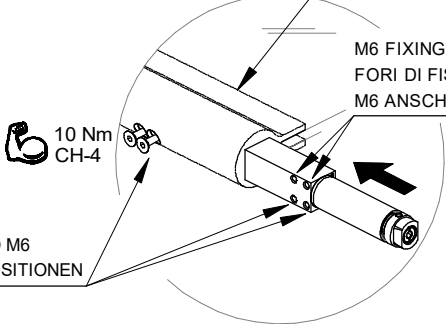

10 Nm  
CH-4

## 2

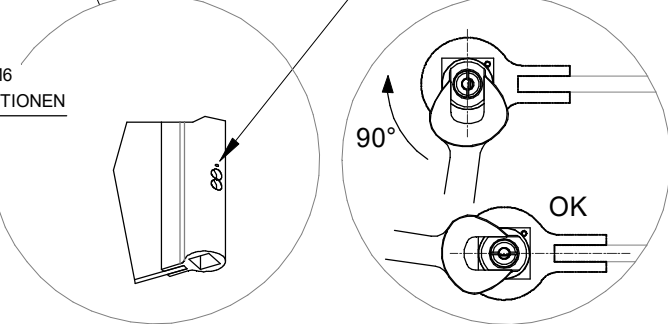

M6 FIXING HOLES  
FORI DI FISSAGGIO M6  
M6 ANSCHRAUBPOSITIONEN

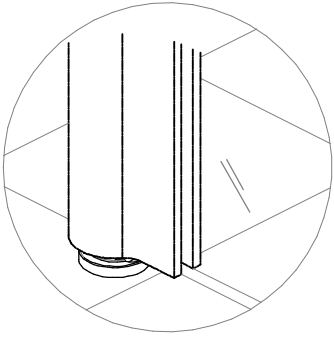

## 3

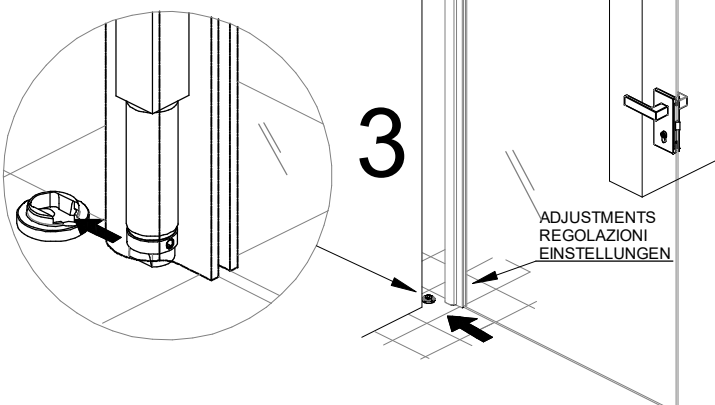

Fittings not included  
Fissaggi non inclusi  
Befestigungsschrauben

2 x

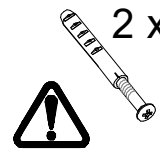

MAX screw  $\varnothing 5$  mm

MAX  $\varnothing 10$  [3/8"]

90°

17.5 [11/16"]

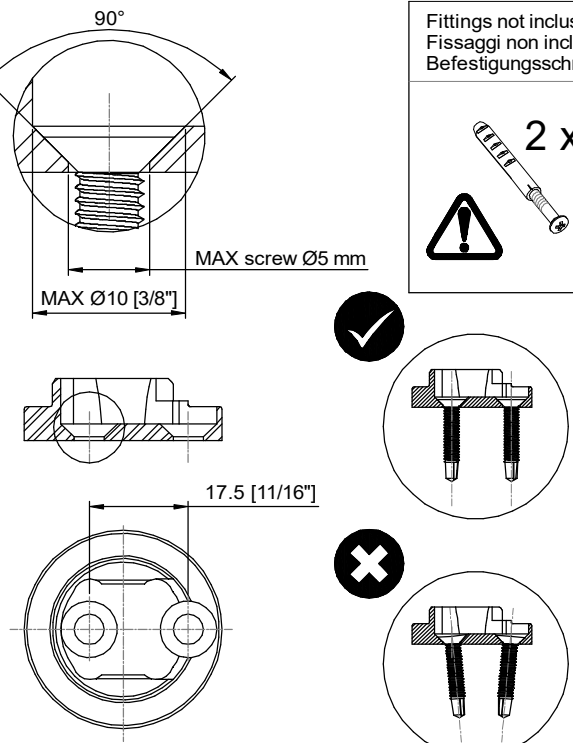



Fittings not included  
Fissaggi non inclusi  
Befestigungsschrauben

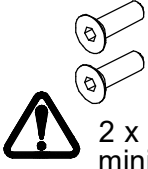

2 x M6  
minimun

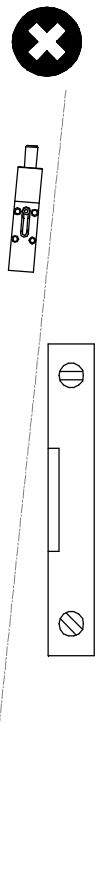
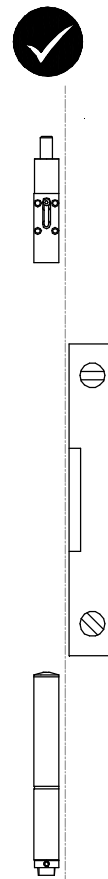
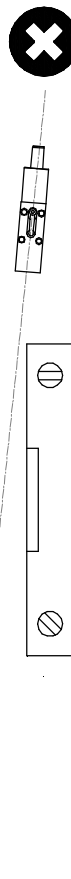
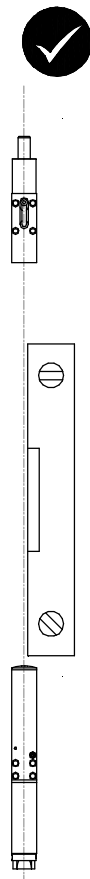
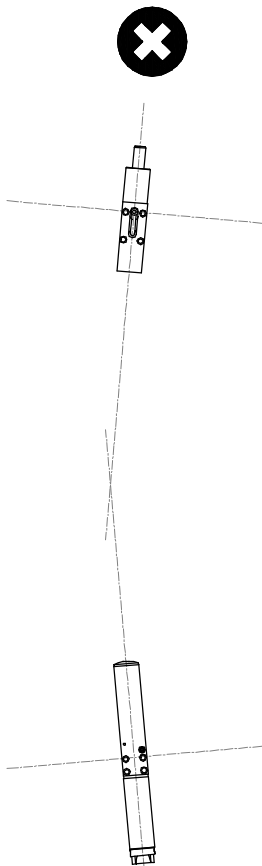
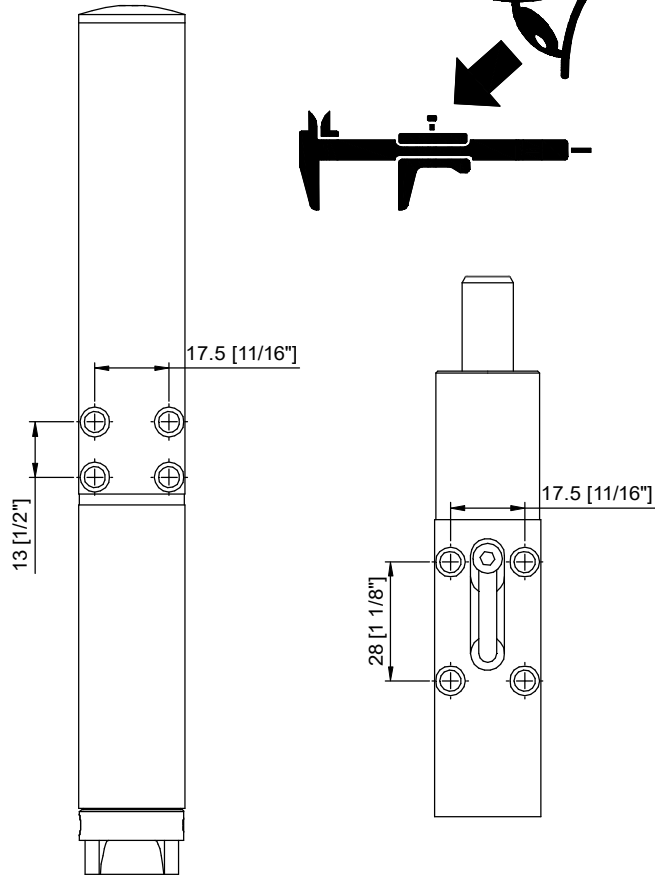
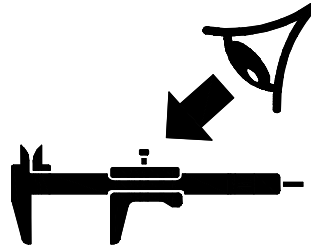



## 4

Closing speed adjustment

Factory settings: average pre-set

Regolazione della velocità di chiusura

Impostazioni di fabbrica: media preimpostata

Einstellung Schließgeschwindigkeit

Werkseitige Konfiguration: durchschnittliche Voreinstellung

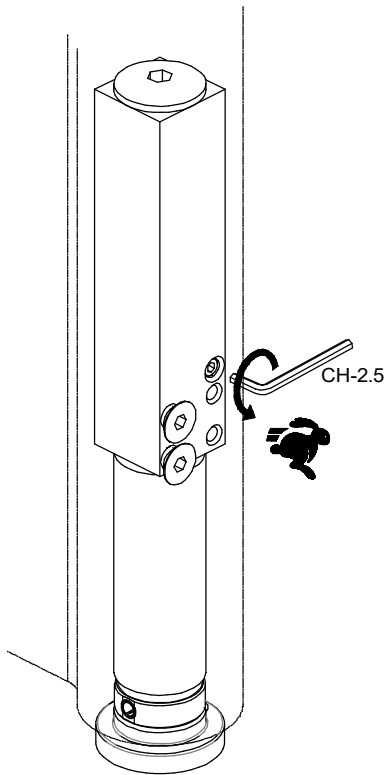

FAST - VELOCE - SCHNELL

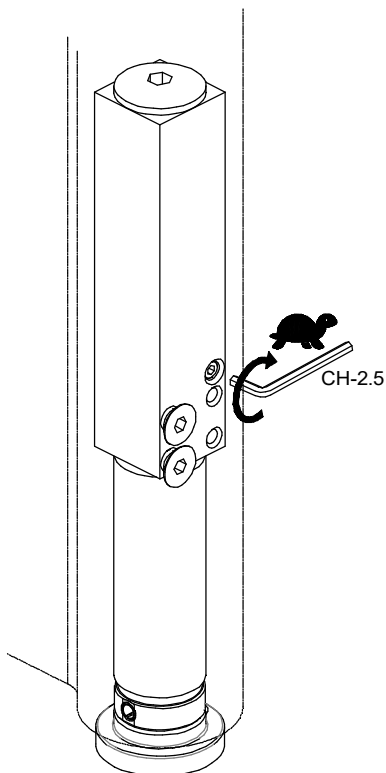
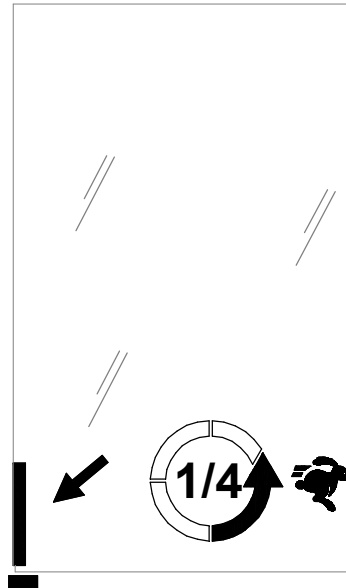

SLOW - LENTO - LANGSAM

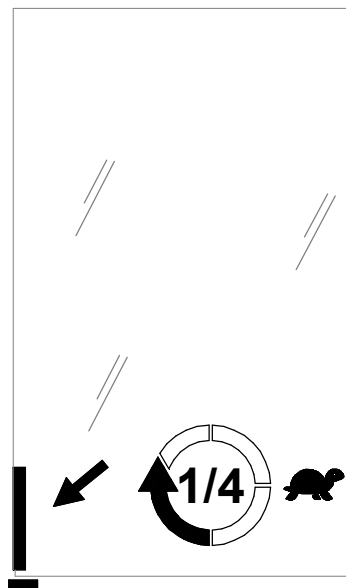

# VERTO

## 845E10 - 845E20

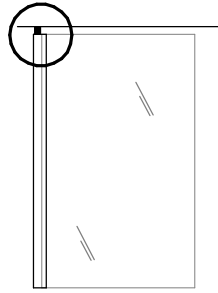
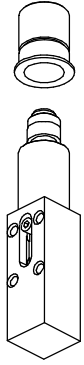

Fittings required  
Fissaggi richiesti  
Benötigtes Befestigungsmaterial

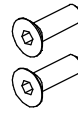

minimum  
2x M6

Tools Required  
Strumenti Richiesti  
Benötigtes Werkzeug

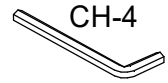

M6 FIXING HOLES  
FORI DI FISSAGGIO M6  
M6 ANSCHRAUBPOSITIONEN

1

EXAMPLE FRAME  
CORNICE DI ESEMPIO  
BEISPIEL RAHMEN

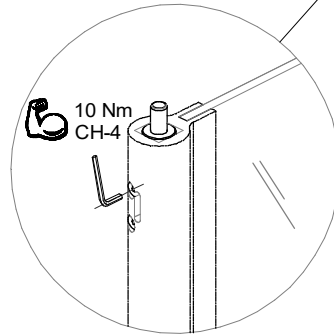
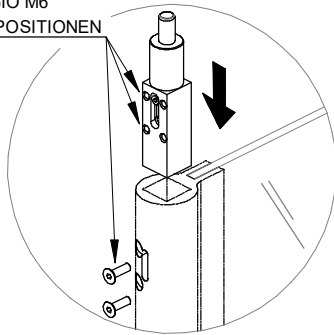

2

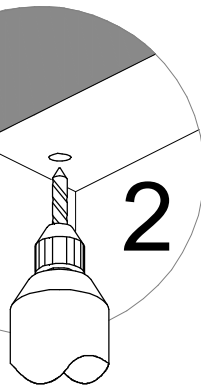

3

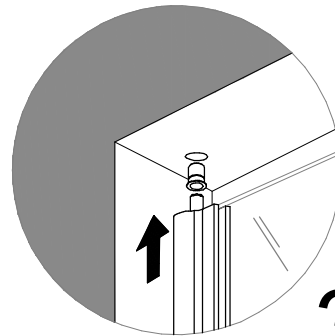

TIGHTEN  
AVVITARE  
ANZIEHEN

